

# ETX-204A

## Carrier Ethernet Demarcation Device



Flexible demarcation device with timing over packet capabilities

- Carrier-class Ethernet demarcation device with full support for Synchronous Ethernet (ITU-T G.8262) and cellular backhaul synchronization applications, including 1588-2008 end-to-end transparent clock
- MEF certified, supporting Ethernet Private Line (EPL) and Ethernet Virtual Private Line (EVPL) services with flexible mapping of user traffic into Ethernet flows
- Robust bandwidth control mechanism and Service Level Agreement (SLA) monitoring per Ethernet flow starting at customer premises
- Complete Ethernet OAM solution based on IEEE 802.3-2005 (formerly 802.3ah), IEEE 802.1ag-D8, and ITU-T Y.1731 for Opex reductions
- Test throughput across routed/switched networks up to line rate by using Layer-2/3 loopback on single or multiple flows simultaneously

**EtherAccess**

**SyncToP**

ETX-204A is a carrier Ethernet demarcation device owned and operated by the service provider and installed at the customer premises. It is the first demarcation device in the market that in addition to its demarcation capabilities provides full support for the Synchronous Ethernet (SyncE) transfer network with user clock synchronization for IP node B backhauling.

ETX-204A is part of RAD's EtherAccess® portfolio and features Carrier Ethernet attributes, including Ethernet OAM for proactive SLA monitoring, quality of

service (QoS) per Ethernet flow, advanced traffic management capabilities, and powerful bandwidth profiles for differentiated services – all starting at the service handoff points.

The ETX-204A SyncToP™ suite includes Synchronous Ethernet and a built-in input/output clock interface. The device can use SyncE to receive the clock from the network, or can transparently forward via IEEE 1588v2 with accurate timestamps.



**RAD**

**data communications**  
The Access Company

# ETX-204A

## Carrier Ethernet Demarcation Device

### FLEXIBLE PORT OPTIONS

ETX-204A is equipped with two Ethernet network ports, supporting link protection based on 802.3ad or dual homing for increased service resiliency. The network and user ports use SFP/UTP combo ports that can operate as fiber optic SFP-based interfaces or electrical RJ-45 interfaces.

### FLEXIBLE TRAFFIC MAPPING

Traffic is mapped to the Ethernet flows (EVCs) using very flexible classification criteria that can be combined, for example:

- Port-based (All-to-one bundling)
- VLAN + VLAN priority
- VLAN + IP precedence
- VLAN + DSCP
- Ether Type
- IP/MAC source/destination address
- Untagged.

More classification criteria and combinations can be found in the user manual.

### QOS

Different service types require different levels of QoS to be provided end-to-end. QoS can be defined per subscriber as well as per service. QoS has three aspects: rate limitation, traffic shaping, and traffic prioritization.

Traffic policing is applied per flow or group of flows, and operates according to the dual token bucket mechanism based on user-configurable CIR + CBS and EIR + EBS. Traffic can be limited to the line rate or the data rate.

For prioritizing user traffic, ETX-204A maps user traffic to up to eight separate queues per service. Each can be configured as strict priority queues or weighted fair queues (WFQ).

The queues handle traffic with different service demands, such as real-time traffic, premium data, or best-effort data.

The device uses the WRED policy to ensure that queues are not congested and high-priority traffic is not dropped.

### TYPICAL APPLICATIONS

ETX-204A is used in the following MEF-defined applications:

- IP Node B backhauling – ETX-204A acts as a transport demarcation device, connecting the base station to the packet network. This provides a clear demarcation between the service domain and the transport domain with proactive service monitoring and easy fault localization throughout the entire network (see *Figure 1*).
- Ethernet Private Line (EPL) – Site-to-site connectivity over dedicated bandwidth without service multiplexing (see *Figure 2*)
- Ethernet Virtual Private Line (EVPL) – Site-to-site connectivity over shared bandwidth with service multiplexing (see *Figure 3*)
- Ethernet LAN – Site-to-site connectivity over dedicated bandwidth with or without service multiplexing.

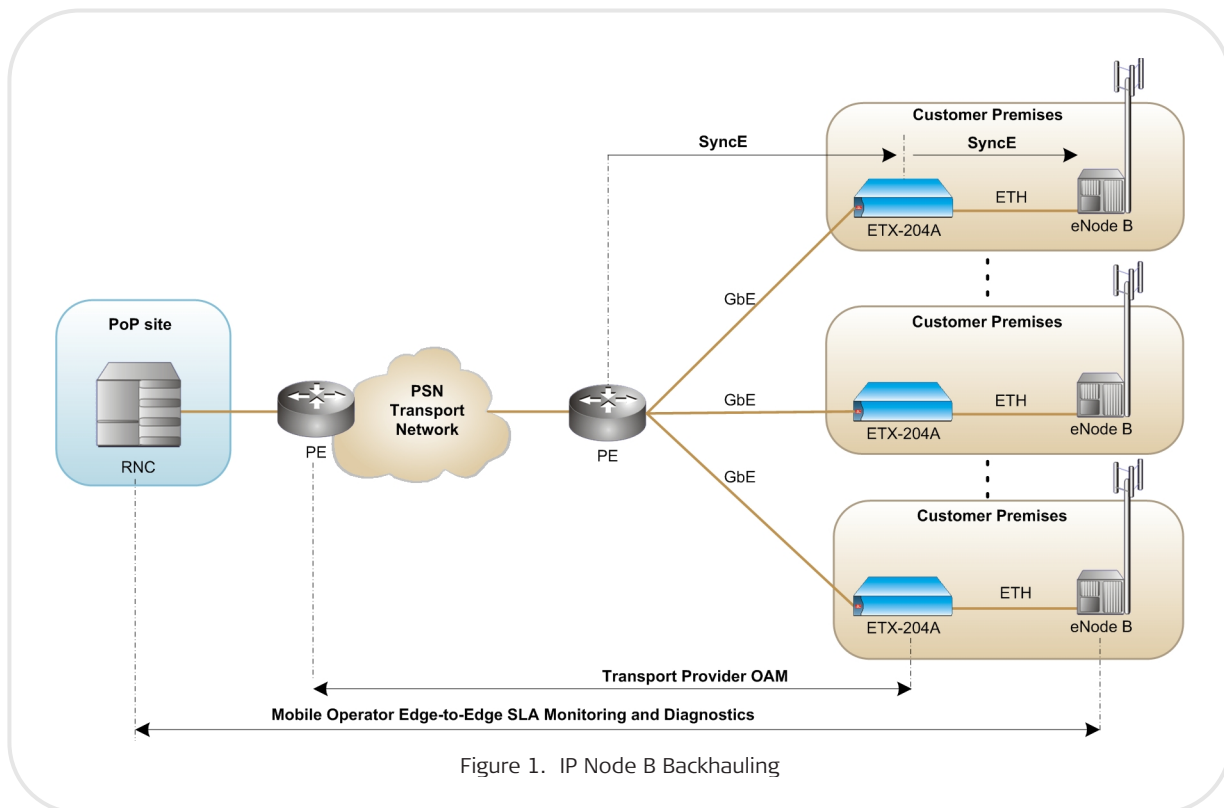

Figure 1. IP Node B Backhauling

## CELLULAR BACKHAUL SYNCHRONIZATION

ETX-204A provides powerful synchronization capabilities, ensuring highly accurate, seamless delivery of 2G, 3G, and 4G traffic over packet backhaul. This enables mobile operators and transport providers to eliminate the risk of service disruptions, impaired cell handoffs, and excessive dropped calls, thereby supporting reliable transmission of real-time traffic over PSNs.

The device also ensures QoS priorities for clock traffic and supports “SDH/SONET or Better” performance requirements for voice and video traffic, such as up to +/-16 ppb (parts per billion) frequency accuracy.

## CLOCK SYNCHRONIZATION

ETX-204A provides robust clock synchronization and flexible timing modes, including synchronization over packet transport networks (SyncE). The clock synchronization is performed according to the ITU-T G.8261/G.8262 requirements.

## MANAGED QOS IN NEXT-GENERATION RADIO ACCESS NETWORKS

ETX-204A delivers managed quality of service in next-generation radio access networks (RANs), allowing mobile operators to enhance their 3.5G/4G service performance by combining Ethernet aggregation with OAM and SLA enforcement capabilities – starting at the eNodeB, HSDPA base station, or WiMAX cell site.



Figure 2. Ethernet Private Line

## ETHERNET OAM

ETX-204A provides these types of Ethernet OAM:

- Single-segment (link) OAM according to IEEE 802.3-2005 (formerly 802.3ah) for remote management and fault indication, including remote loopback, dying gasp, and MIB parameter retrieval. Active and passive mode are supported.
- End-to-end connectivity OAM based on IEEE 802.1ag-D8 that enables Ethernet service providers to monitor their services proactively and guarantee that customers receive the contracted SLA
- End-to-end service and performance monitoring based on ITU-T Y.1731. Fault monitoring and end-to-end performance measurement include frame delay, frame delay variation, frame loss and availability.

## SFP/UTP COMBO PORTS

The SFP/UTP combo Ethernet ports are FE/GbE auto detecting and can accommodate a wide range of Fast Ethernet and Gigabit Ethernet SFP transceivers, allowing service providers to seamlessly connect customers located at different distances from the device.

## COMMAND LINE INTERFACE

Databases and scripts of commonly used commands can be easily created and applied to multiple units using command line interface.

## HIERARCHICAL SCHEDULING AND SHAPING PER FLOW

Every flow has its own queues and scheduler. ETX-204A supports up to 220 services, and a total of 30 queue blocks per network port. Each queue block is a group of eight queues per CoS. Each flow can be bound to each queue block.

## L2CP HANDLING

ETX-204A can be configured to pass through Layer-2 control frames (including other vendors' L2CP frames) across the network, to peer supported protocols (IEEE 802.3-2005 and LACP), or to discard the L2CP frames.

## IEEE-1588V2 TRANSPARENT CLOCK

ETX-204A is aware of 1588v2 timing packets, hence when it is necessary for the device to transport them, it forwards them in a way designed to ensure minimal effect of packet delay variation according to the IEEE-1588 End-to-End TC standard.

## TRAP SYNCHRONIZATION

Traps are sent with sequence IDs to network manager groups, to enable the managers to detect when traps are lost and request the traps be sent again.

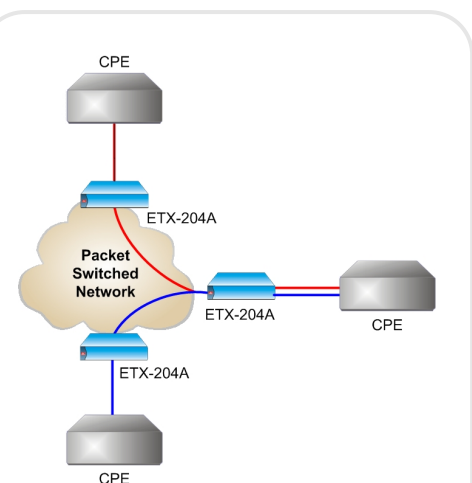

Figure 3. Ethernet Virtual Private Line

Powerful  
synchronization  
capabilities ensuring  
seamless delivery over  
packet backhaul

### LAYER-2/ LAYER-3 LOOPBACK WITH MAC AND IP ADDRESS SWAPPING

As services and networks become more complex, tracking service and network faults is very important for conforming to the SLA. Therefore it is vital that the service provider can perform network loopbacks to easily track failures. Layer-2 and/or layer-3 network integrity can be tested by a non-disruptive loopback performed per flow, with swapping of MAC address and optionally IP address. When the loopback is activated, ETX-204A exchanges the source and destination MAC/IP addresses of the incoming packets. This loopback passes through Ethernet bridges (MAC address) and routers (IP address).

### NETWORK INTERFACE REDUNDANCY

Two redundancy modes can be applied:

- Link aggregation (LAG) based on 802.3ad
- Dual homing (1:1), allowing ETX-204A to be connected to two different upstream devices.

### JUMBO FRAMES AND EGRESS MTU

The unit supports large frames of up to 12 Kbytes.

### ENVIRONMENT

ETX-204A/H is a temperature-hardened version with matching SFPs intended for industrial installations, available in both 19" and 8.5" enclosures.

### COLOR-AWARE P-BIT RE-MARKING

The VLAN priority bit in Ethernet frames can be modified at network ingress according to the 'color' of the frame. This allows service consistency and QoS continuity across color-aware (Drop Eligible-enabled) as well as color-unaware networks.

### FAULT PROPAGATION

The unit provides a user-configurable fault propagation mechanism in the network-to-user or user-to-network direction. When a link failure is detected or OAM failure received, ETX-204A can shut down the affected port or forward the OAM failure message. The fault propagation mechanism enables routers and switches connected to both ends of the link to reroute the traffic to the redundancy path.

### DYING GASP

ETX-204A reports power failures to defined network management stations by sending an IEEE 802.3-2005 message and trap, thus enabling the unit to properly disconnect from the network with notification of the reason for the service problem.

## MANAGEMENT

The unit can be managed using the following ports and applications:

- Local management via an ASCII terminal connected to the RS-232 port
- Remote inband management via user or network ports routed via separate VLANs, Telnet, or RADview, RAD's SNMP-based management system
- Out-of-band management via a dedicated management port
- SFTP – Secure File Transfer Protocol.

## SECURITY

The following security protocols are provided by ETX-204A to ensure client server communication privacy and correct user authentication:

- SNMPv3
- RADIUS (client authentication only)
- SSH for Secure Shell communication session.

## DHCP

IP address, IP mask, and default gateway can be automatically obtained using DHCP.

## Specifications

### NETWORK INTERFACE

#### Number of Ports

Up to 2 (redundancy)

#### Type

SFP/UTP combo port:

Fiber optic:

Fast Ethernet (100BaseFx, 100BaseLX10, 100BaseBx10, 100BaseT), SFP-based  
Gigabit Ethernet (1000BaseSx, 1000BaseLX10, 1000BaseBx10, 1000BaseT), SFP-based

Copper: 10/100/1000BaseT (built-in)

#### Connector

SFP slot or RJ-45

#### SFP Transceivers

For full details, see the SFP Transceivers data sheet at [www.rad.com](http://www.rad.com)

**Note:** *It is strongly recommended to order this device with **original RAD SFPs installed**. This will ensure that prior to shipping, RAD has performed comprehensive functional quality tests on the entire assembled unit, including the SFP devices. RAD cannot guarantee full compliance to product specifications for units using non-RAD SFPs.*

### USER INTERFACE

#### Number of Ports

Up to 5

#### Type

SFP/UTP combo port

#### Connector

SFP slot or RJ-45

#### SFP Transceivers

For full details, see the SFP Transceivers data sheet at [www.rad.com](http://www.rad.com)

### EXTERNAL CLOCK PORT

External input or output via optional dedicated E1 or 2.048 MHz port (G.703), RJ-45 connector

### MANAGEMENT PORTS

#### Out-of-Band Ethernet Management Port

Type: 10/100BaseT

Connector: RJ-45

#### Control Port

Interface: V.24/RS-232 DCE

Connector: 9-pin D-type, female

Format: Asynchronous

Data rate: 9.6, 19.2, or 115.2 kbps

# ETX-204A

## Carrier Ethernet Demarcation Device

### GENERAL

#### Max. Frame Size

12,288 bytes

#### Certifications

MEF 9, MEF 14: EPL and EVPL

#### Compliance

MEF 6 (E-Line – EPL and EVPL), MEF 10  
IEEE 802.3, 802.3u, 802.1d, 802.1q,  
802.1p, 802.3ad, 802.3-2005,  
802.1ag-D8, ITU-T Y.1731

### Indicators

PWR (green):

On – ETX-204A is powered up

TST/ALM (red):

On – One of the Ethernet links is down

Blinking – Diagnostic loopback is active

LINK/ACT ETH (green):

On – Ethernet link OK

Blinking – Data is being transmitted

and received on the Ethernet link

LINK/ACT EXT CLK (green):

On – Station clock port connected

### Power

AC power supply:

100–240 VAC, 50/60 Hz

DC power supply:

48V (-48 to 72VDC)

24V (20 to 32VDC)

### Power Consumption

18.5W max

### Physical

Unit with single power supply:

Height: 43.7 mm (1.7 in)

Width: 215 mm (8.4 in)

Depth: 300 mm (11.8 in)

Weight: 2.4 kg (5.2 lb)

Unit with dual power supply:

Height: 43.7 mm (1.7 in)

Width: 440 mm (17.4 in)

Depth: 240 mm (9.5 in)

Weight: 3.1 kg (6.8 lb)

### Environment



Temperature:

ETX-204A: 0–50°C (32–122°F)

ETX-204A/H: -40 to 65°C (-40 to 149°F)

Humidity: Up to 90%, non-condensing

Table 1. ETX Family Comparison Table

Feature	ETX-203A (Ver. 3.02)		ETX-204A (Ver. 2.23)
			
Function	Basic NTU	Advanced NTU	Premium NTU
Bandwidth	100 Mbps per port	100/1000 Mbps per port	100/1000 Mbps per port
Ethernet Ports (Net/net/user)	1/1/2 SFP/UTP	1/1/2 SFP/UTP	1/1/2 or 1/1/4 SFP/UTP Combo
Network interface	Up to 2 × Fast Ethernet	Up to 2 × Gigabit or Fast Ethernet	Up to 2 × Gigabit or Fast Ethernet SFP/UTP combo ports
User interface	Up to 3 × Fast Ethernet	Up to 3 × Gigabit or Fast Ethernet	Up to 5 × Gigabit Ethernet SFP/UTP combo ports
Number of flows (EVC.cos) / shapers / MEPs	192/2/128	192/30/128	192/30/64
Service type	EPL and EVPL (flow-based)		EPL and EVPL (flow-based)
Forwarding mode	Flow-based forwarding		Flow-based forwarding
Management interface	Command line		Command line
G.8031 protection	Yes		No
QoS	Rate limitation per flow Traffic classification (Port-based, VLAN, 802.1p bits, ToS, DSCP) Shaping		Rate limitation per flow Traffic classification (Port-based, VLAN, 802.1p bits, ToS, DSCP) Shaping
Bandwidth profile	CIR/CBS, EIR/EBS per EVC.COS		CIR/CBS, EIR/EBS per EVC.COS
RFC-2544 testing	Yes		No
Max. frame size	12,288 bytes		12,288 bytes
T1/E1, T3/E3, OC-3/STM-1 bridging	Supported, includes integrated management		No
Timing options	No		Yes (SyncE)
Temperature-hardened option	No		Yes
Power supply	Universal AC/DC		AC or DC
Power supply redundancy	No		Yes

## ETX-204A

## Carrier Ethernet Demarcation Device

## Ordering

## STANDARD CONFIGURATIONS

ETX-204A/AC

ETX-204A/DC/4

ETX-204A/AC/4

ETX-204A/DCR/H/4

ETX-204A/ACR/4

ETX-204A/AC/19/SYE

ETX-204A/DC/19/PTP

## SPECIAL CONFIGURATIONS

ETX-204A /?/!|BT/B/\_

## Legend

? Temperature range (Default=Regular enclosure):

H Temperature-hardened enclosure

**Note:** The ETX-204A/H version requires industrially-hardened SFP transceivers.

! Power supply (Default=Single AC power supply in 1U 8.5" enclosure):

AC Single AC power supply

DC Single DC power supply (-48DC)

24DC Single DC power supply (24DC)

ACR Dual AC power supply in 1U 19" enclosure

DCR Dual DC power supply (-48DC) in 1U 19" enclosure

24DCR Dual DC power supply (24DC) in 1U 19" enclosure

BT Enclosure (Default=19" metal enclosure if ACR/DCR ordered, otherwise default=8.5" metal enclosure if AC/DC ordered):

19 19" metal enclosure

**Note:** Units with dual power supplies require the 19" enclosure.

- B Number of user ports (Default=2 user ports):
- 4 4 user ports
- Timing (Default=No hardware support for synchronization over packet):
- SYE SyncE full support

## SUPPLIED ACCESSORIES

AC power cord

DC connection kit (if DC power supply is ordered)

## OPTIONAL ACCESSORIES

- ! Power supply
- AC Single AC power supply
- DC Single DC power supply (-48DC)
- 24DC Single DC power supply (24DC)

## RM-34

Hardware kit for mounting one ETX-204A unit with 19" enclosure in a 19" rack

## RM-35/+

Hardware kit for mounting one or two ETX-204A units with 8.5" enclosure in a 19" rack

- + Rack mount kit (Default=Both kits):
- P1 Kit for mounting one unit
- P2 Kit for mounting two units

## WM-34

Hardware kit for mounting one ETX-204A unit with 19" enclosure on a wall

## WM-35

Hardware kit for mounting one ETX-204A unit with 8.5" enclosure on a wall

## CBL-DB9F-DB9M-STR

Control port cable

## CBL-RJ45/2BNC/E1/X

Adaptor cable for converting a balanced E1 interface to an unbalanced E1 interface, with an RJ-45 balanced connector and two unbalanced BNC coaxial connectors

**International Headquarters**  
24 Raoul Wallenberg Street  
Tel Aviv 69719, Israel  
Tel. 972-3-6458181  
Fax 972-3-6498250, 6474436  
E-mail market@rad.com

**North America Headquarters**  
900 Corporate Drive  
Mahwah, NJ 07430, USA  
Tel. 201-5291100  
Toll free 1-800-4447234  
Fax 201-5295777  
E-mail market@rad.com

www.rad.com

Order this publication by Catalog No. 803922



data communications

The Access Company