

ASMi-54

SHDSL.bis Modem



Metal Enclosure

Plastic Enclosure

Rail-mount Metal Enclosure

19-inch Metal Enclosure

High-end SHDSL.bis multiservice access equipment

- SHDSL.bis managed modem operating at full-duplex data rates of up to 5.7 Mbps per copper pair
- Ethernet service over 8-wire line of up to 22.8 Mbps in Point-to-Point, Multipoint, Daisy Chain and Ring topologies
- Two platforms for Ethernet encapsulation with up to 22 Mbps throughput over 8-wire lines: HDLC and SHDSL EFM bonding (in Point-to-Point topology)
- Optional 4xE1 service in addition to HDLC encapsulated Ethernet in Multipoint, Daisy Chain and Ring topologies



ASMi-54

SHDSL.bis Modem

ASMi-54 is a simple, cost-effective, dedicated managed SHDSL.bis modem that extends the range of high-speed services over existing copper pairs.

The modem features a variety of topologies, which extend up to 4 E1 and 4 ETH ports with integrated switch to the SHDSL line.

ASMi-54 operates in the following topologies:

- Point-to-Point – extending traffic on four Ethernet links at rates of up to 22.8 Mbps (EFM bonding)
- Daisy-chain and Ring topologies for Ethernet connectivity – ASMi-54 enables service resiliency and protection by implementing the ITU-T G.8032 ETH ring protection switching standard for bandwidth of up to 11.4 Mbps
- Multipoint – each ASMi-54 operates with four ASMi-54L modems to enable extension of E1 and HDLC-encapsulated Ethernet traffic, while connectivity towards the IP network can be either copper or fiber, using an SFP transceiver
- Point-to-Point – four Ethernet links (HDLC encapsulation) in addition to four E1 ports, up to 22.8 Mbps.

Table 1 illustrates the topologies and features supported by selected ASMi-54 options.

The modem also features line probing according to G.991.2. When enabled, the SHDSL interface adapts its rate to the condition of the line (noise, loop attenuation, etc.). When disabled, the SHDSL line operates at a fixed rate selected by the user.

ASMi-54 can operate as a CO device or a CPE device according to user configuration.

EFM BONDING

EFM bonding on the Ethernet interface ensures that a failure or addition of a link does not drop the traffic being transmitted over the other wires in the group. The capacity of the group does not decrease when a new link is added at a lower rate.

The modem transports Ethernet point-to-point at the rate of up to 22.8 Mbps using EFM bonding technology, which enables each link to synchronize at a different rate.

Note: This feature relates to Ethernet service in point-to-point topology only (see Table 1 for details).

ETHERNET SUPPORT

ASMi-54 features up to four Ethernet 10/100BaseT ports with half/full-duplex autonegotiation and flow control.

Fault propagation enables the unit to shut down the Ethernet user port when an SHDSL line failure is detected. LANs are connected by bridging.

The internal forwarding of Ethernet traffic can be configured by:

- Specifying the ports (a mode identified as *unaware* in accordance with Metro Ethernet Forum (MEF) standards). In this mode, all the Ethernet traffic reaching one of the ports is forwarded to the other port, and vice versa
- Using VLANs for classification (a mode identified as *aware* in accordance with Metro Ethernet Forum (MEF) standards). In this mode, Ethernet traffic reaching one of the ports is forwarded to another port in accordance with its VLAN identifier.

QUALITY OF SERVICE

The 802.1D DSCP schemes allow users to define different QoS levels according to application requirements.

The modem implements the IEEE's 802.1q standards to provide VLAN-tagging with four levels of prioritization, enabling carriers to offer differentiated Ethernet services.

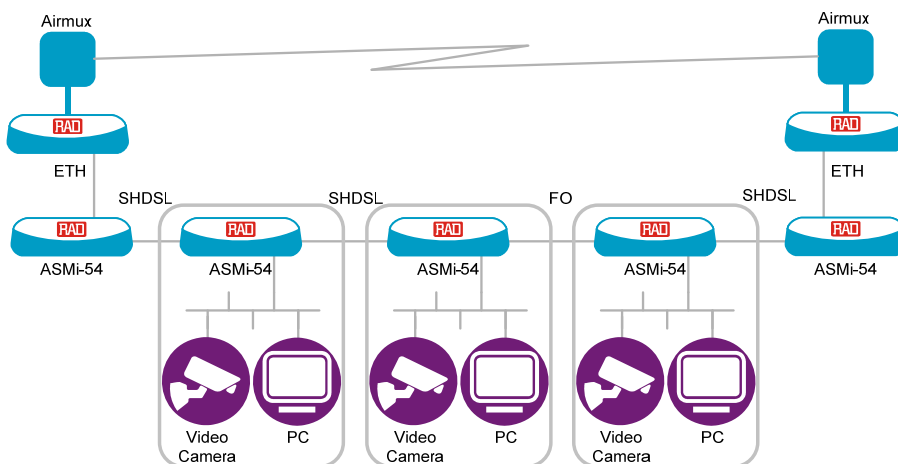

Figure 1. Daisy Chain over any Infrastructure for HDLC-Encapsulated Ethernet

VLAN tagging can also be employed to separate traffic, ensuring transparency of the customer traffic and bolstering security of management traffic. The user can activate or deactivate the priority mechanism, and each priority (VLAN priority, DSCP) can be configured and mapped to one of four priority queues.

MANAGEMENT

The ASMi-54 unit can be managed using the following connections:

- Local RS-232 terminal
- Telnet server, SNMP (Ver.1)
- Web-based management application
- Inband management with or without dedicated VLAN.

Up to eight SHDSL repeaters can be installed in-line to increase the operation range of E1- and Ethernet-based modems.

POWER

ASMi-54 is available with several power options:

- AC/DC wide-range (100 to 240 VAC, -48 to -60 VDC nominal)
- Redundant AC/DC wide-range power supply configuration in a 1U-high 19-inch metal enclosure (Ring and Daisy-chain topology only)
- 24 VDC
- Via power feeding of DC voltage over the SHDSL line (4-wire and 8-wire Ethernet versions only).

PHYSICAL

ASMi-54 is supplied in 1U-high plastic, metal (8.5- or 19-inch), or rail-mount enclosures.

Modems with metal and plastic enclosures can be mounted alone or in pairs in a 19-inch rack using RAD's optional mounting kits. Units in metal enclosure can also be mounted in an 8.5-inch rack (see *Ordering*).

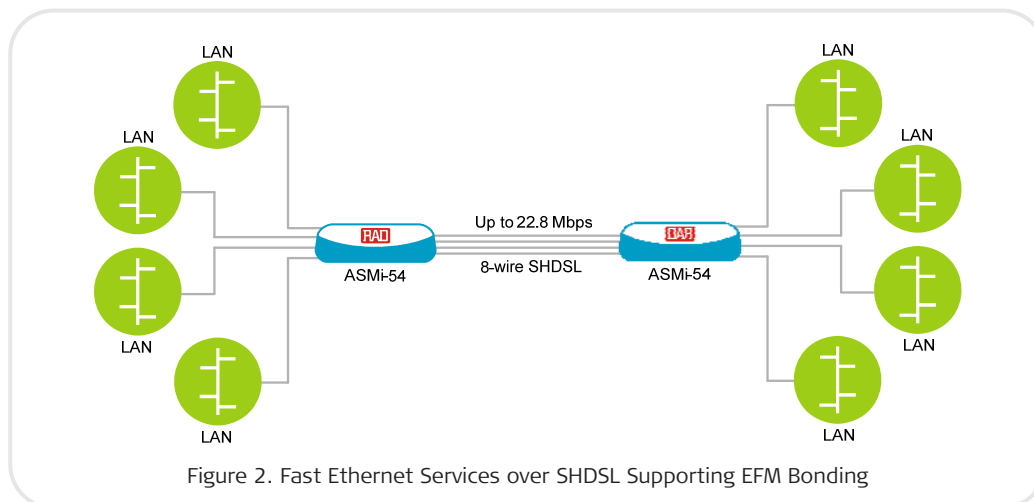

Figure 2. Fast Ethernet Services over SHDSL Supporting EFM Bonding

Table 1. Special Topologies and Features

ASMi-54 Options	Topology	EFM	SFP Socket
ASMi-54/4ETH/8W	<ul style="list-style-type: none"> • Multipoint opposite LRS-102, Megaplex-4100 or ASMi-54L • Point-to-Point 	Yes	No
ASMi-54/4E1/4ETH/8W	<ul style="list-style-type: none"> • Multipoint opposite LRS-102, Megaplex-4100 or ASMi-54L • Point-to-Point 	No	Yes
ASMi-54/4ETH/8W/D	Daisy-chain and Ring	No	Yes
ASMi-54/4ETH/8W/M	Multipoint	No	Yes

ASMi-54

SHDSL.bis Modem

Specifications

SHDSL INTERFACE

Number of Ports

2

Line Type

Symmetrical PSD
8-wires unconditioned dedicated line (twisted pair)

Connectors

RJ-45

EFM Bonding

Per IEEE802.3ah and ITU-T G.991.2

Note: Applicable to Ethernet service in the point-to-point topology only.

Line Coding

16 or 32 TC-PAM

Frame Size

EFM: 1580 bytes
HDLC: 1530 bytes (while working with E1 or repeaters)

Line Rate

EFM: 192 to 5696 kbps in steps of n x 64 kbps for each 2-wires
HDLC: 192 to 22784 kbps in steps of n x 64 where n = 89/178/356 for 2W/4W/8W

Range

Typical Ranges
(26 AWG, noise-free)

Data Rate [kbps]	2-wire	
	[km]	[miles]
192	6.6	4.1
1536	4.9	3.0
2048	4.5	2.8
4096	3.2	2.0
4608	3.0	1.9
5696	2.6	1.6

Impedance

135Ω

Compliance

ITU-T G.991.2, ETSI TS 101524

E1 INTERFACE

Number of Ports

4 x RJ-45

Coding

HDB3

Line Impedance

120Ω, balanced
75Ω, unbalanced (via adapter cable)

Jitter Performance

As per ITU G.823

Connectors

RJ-45

Diagnostics

Local analog loopback
Remote digital loopback

ETHERNET INTERFACE

Number of Ports

4 x UTP
3 x UTP + 1 SFP socket
2 x UTP + 2 SFP socket

Interfaces

10/100BaseT
100BaseFx

Connectors

n x RJ-45
n x SFP

Frame Size

2048 bytes

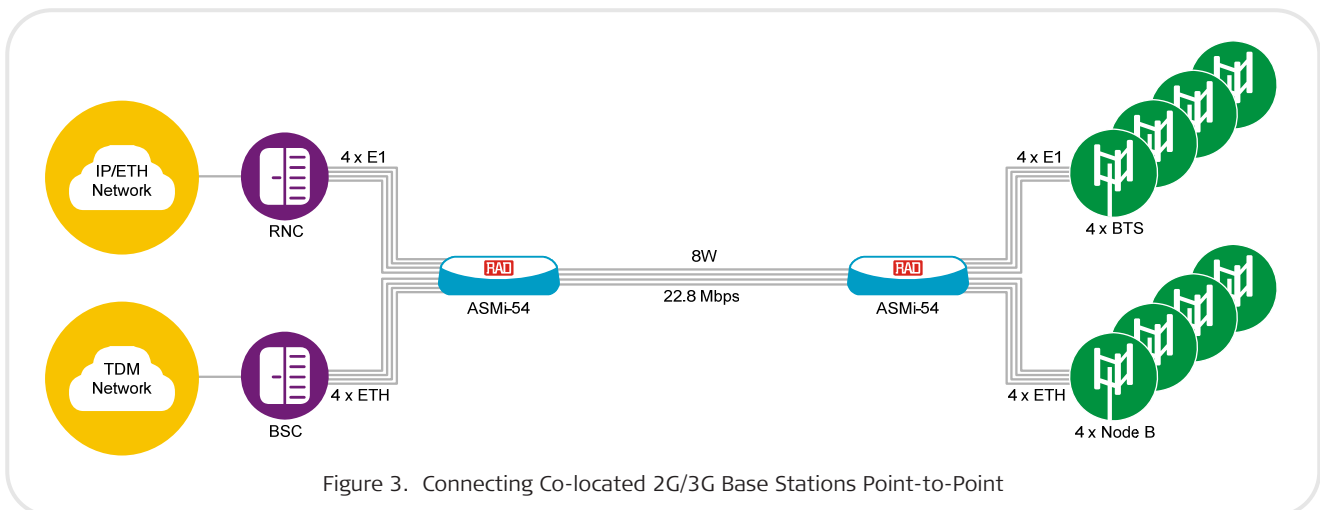

Figure 3. Connecting Co-located 2G/3G Base Stations Point-to-Point

CONTROL PORT

Interface

V.24/RS-232

Type

DCE

Format

Asynchronous; 8 bits, 1 stop bit, no parity

Data Rate

9.6, 19.2, 115.2 kbps

Connector

9-pin, D-type, female

INDICATORS

Front Panel

PWR (green) -

On: power supply is on

TST (yellow) -

On: a test is active

ALM (red) -

On: a new alarm is detected in the alarm buffer

SHDSL SYNC (green/red) -

Green on: at least one line is synchronized and can pass data

Green flashing: no line is synchronized and at least one line is in training process

Red: no line is synchronized, in training process

Rear Panel

Ethernet Ports LINK/ACT (per port)

ACT (yellow) -

Flashing: Ethernet traffic on the port

LINK (green) -

On: Ethernet port link is up

Off: No Ethernet link on the port

E1 LOC (red) -

On: Loss of signal or sync loss (framed mode only) or unframed AIS is received on the E1 port

E1 REM (red) -

On: Remote alarm is received on the E1 port

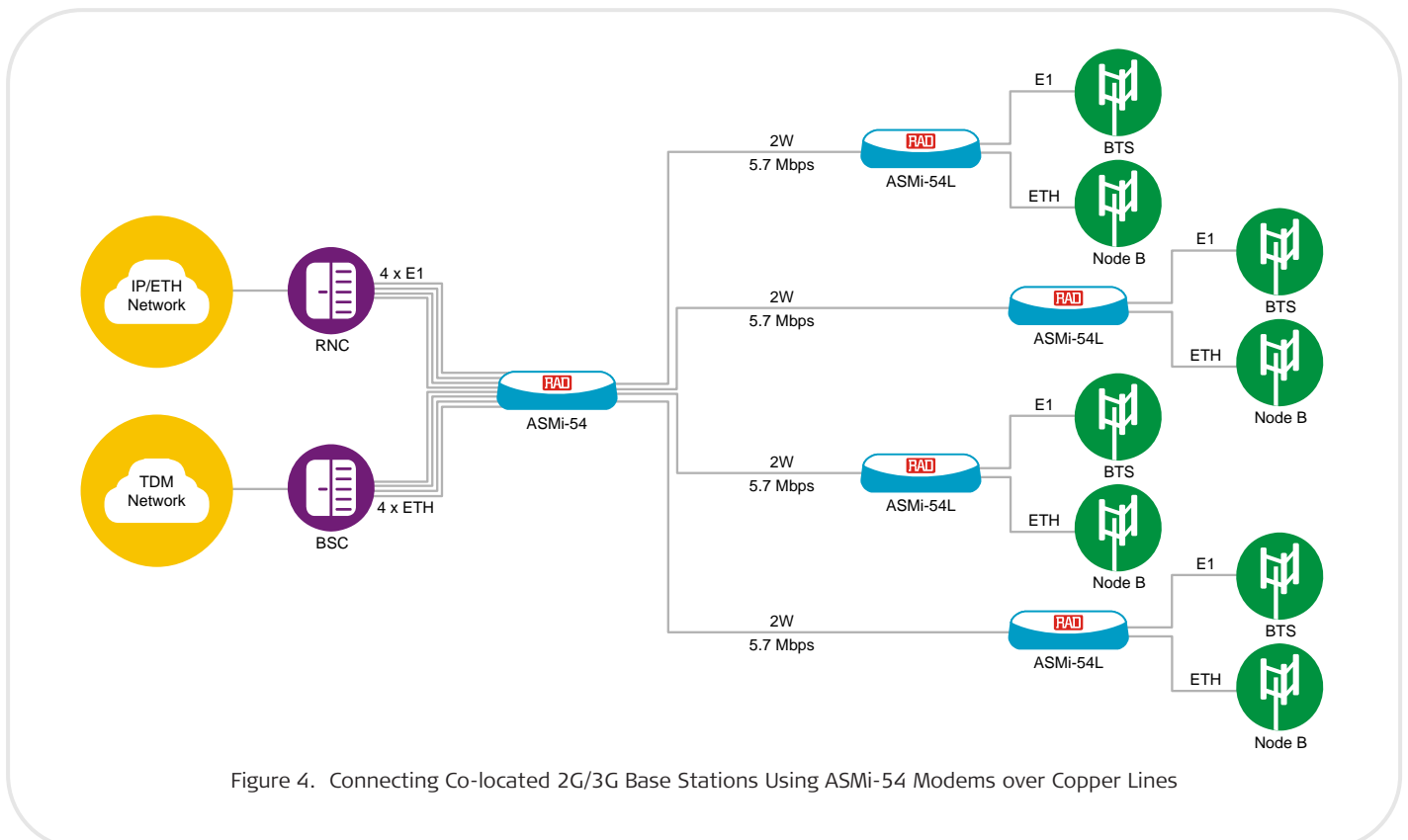

Figure 4. Connecting Co-located 2G/3G Base Stations Using ASMi-54 Modems over Copper Lines

ASMi-54

SHDSL.bis Modem

GENERAL

Power Supply

Wide-range AC/DC: 100 to 240 VAC, -48 to -60 VDC nominal

Note: Redundant AC/DC wide-range power supply configuration is available in a 19-inch metal enclosure (for Ring or Daisy-chain topologies only).

DC: 24 VDC nominal

Remote power feeding

Via SHDSL line, 120 VDC maximum (4-wire or 8-wire, for units with Ethernet service only)

Timing

CO mode:

- Internal – derived from the modem
- External – derived from E1 port

CPE mode:

- Receive – derived from the SHDSL line

Performance Monitoring

SHDSL and E1 statistics collection

Physical

Plastic enclosure:

Height: 43.7 mm (1.7 in)
 Width: 217 mm (8.5 in)
 Depth: 170 mm (6.7 in)
 Weight: 0.6 kg (1.3 lb)

8.5-inch metal enclosure:

Height: 43.7 mm (1.7 in)
 Width: 215.5 mm (8.5 in)
 Depth: 153 mm (6.0 in)
 Weight: 0.7 kg (1.5 lb)

19-inch metal enclosure:

Height: 44 mm (1.7 in)
 Width: 427 mm (17.0 in)
 Depth: 258 mm (10.1 in)
 Weight: 4.0 kg (8.8 lb)

Rail-mount metal enclosure:

Height: 150 mm (5.9 in)
 Width: 70 mm (2.8 in)
 Depth: 163 mm (6.4 in)
 Weight: 0.9 kg (1.9 lb)

Environment

Temperature: 0° to 50°C (32° to 122°F)

Extended temperature (4 x ETH interface version only): -20° to 70°C (-4° to 158°F)

Humidity: Up to 90%, non-condensing

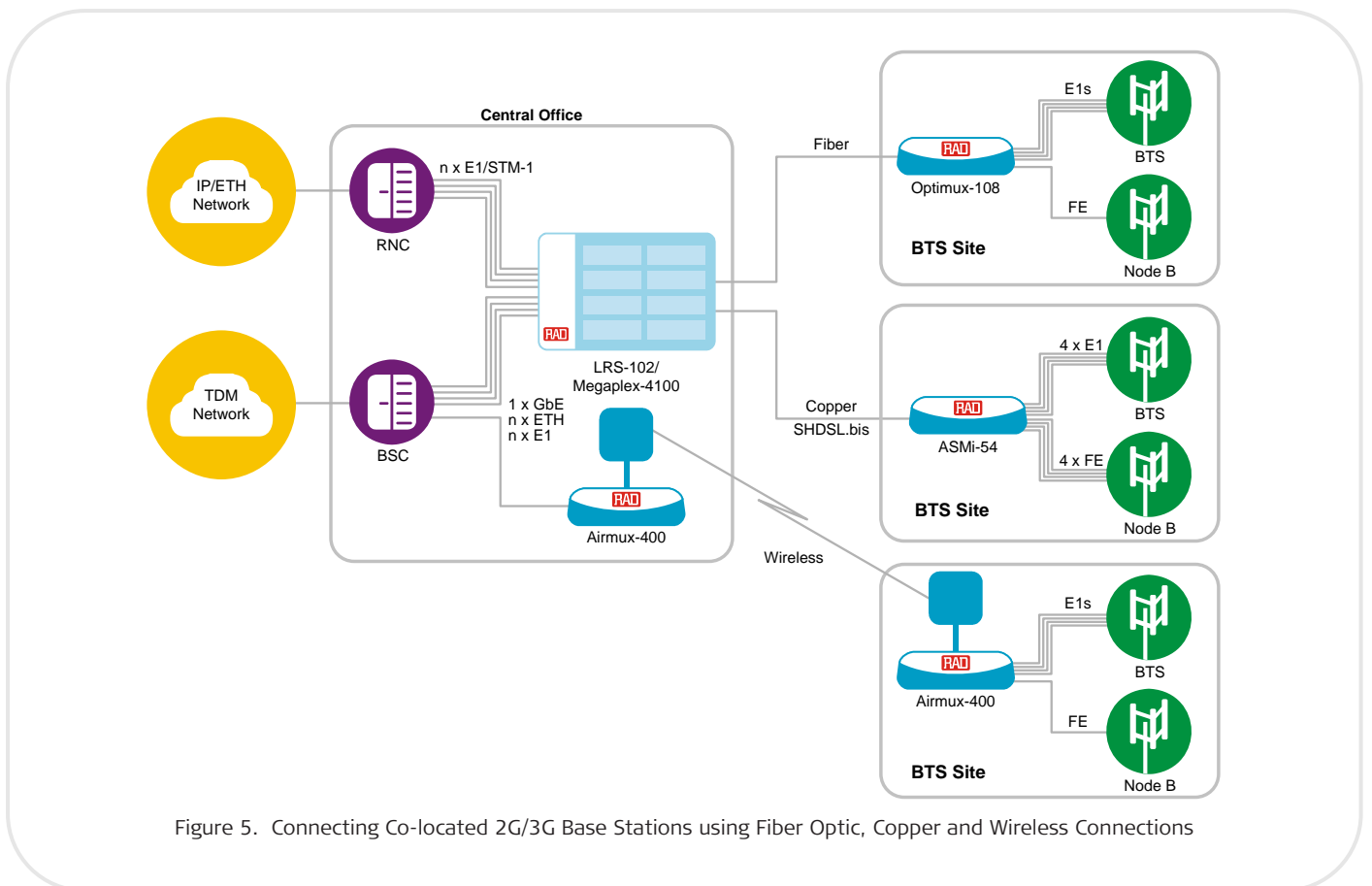

Figure 5. Connecting Co-located 2G/3G Base Stations using Fiber Optic, Copper and Wireless Connections

Ordering

STANDARD CONFIGURATIONS

ASMi-54/4E1/4ETH/8W

ASMi-54/4ETH/8W/1NULL3UTP

ASMi-54/4ETH/8W/M

ASMi-54/4ETH/8W/D

ASMi-54/4ETH/8W/D/R (19-inch metal enclosure with redundant AC/DC wide-range power supply)

SPECIAL CONFIGURATIONS

ASMi-54/\$/@/#/^/*/%/~

Legend

- \$ Power supply (Default= wide-range AC/DC power supply):
 - 24V Optional 24 VDC power supply
- @ User interface (Default=no E1 interface):
 - 4E1 Four E1 ports

- # Ethernet interface (mandatory):
 - 4ETH Four-port ETH module (Default=4 x RJ-45 connectors)
- ^ Extended temperature for device with 4 ETH interfaces (Default=0° to 50°C (32° to 122°F):
 - ETR -20° to 70°C (-4° to 158°F)
 - Note 1:* For 8W/M and 8W/D options ETR is -20° to 65°C (-4° to 149°F).
 - Note 2:* Complies with NEBS for Ethernet services in temperature range -5° to 55°C (23° to 131°F).
- * SHDSL interface:
 - 8W 8-wire (For plastic enclosure with (4ETH + 4E1) option or metal enclosure only)
 - 8W/D 8-wire with daisy-chain/ring capabilities (4W on each side)
 - 8W/M 8-wire with multipoint capabilities
 - Note:* 8W/D and 8W/M interfaces are for Ethernet service only, with no EFM support.

- % Enclosure (Default=plastic enclosure):
 - ME 8.5-inch metal enclosure (For 8W/D or 8W/M options only)
 - RAIL Rail-mount enclosure (For 8W with Ethernet port, 8W/D and 8W/M options only)
- ~ One or two SFP sockets on the ETH interface (Default=4 x RJ-45 connectors, no SPF sockets)
 - 1NULL3UTP SFP socket on Port 1 + UTP Ports 2, 3, 4
 - 2NULL2UTP SFP sockets on Ports 1,2 + UTP Ports 3, 4
 - Note:* For the 4ETH/8W/D, 4ETH/8W/M or 4E1/4ETH/8W options only.

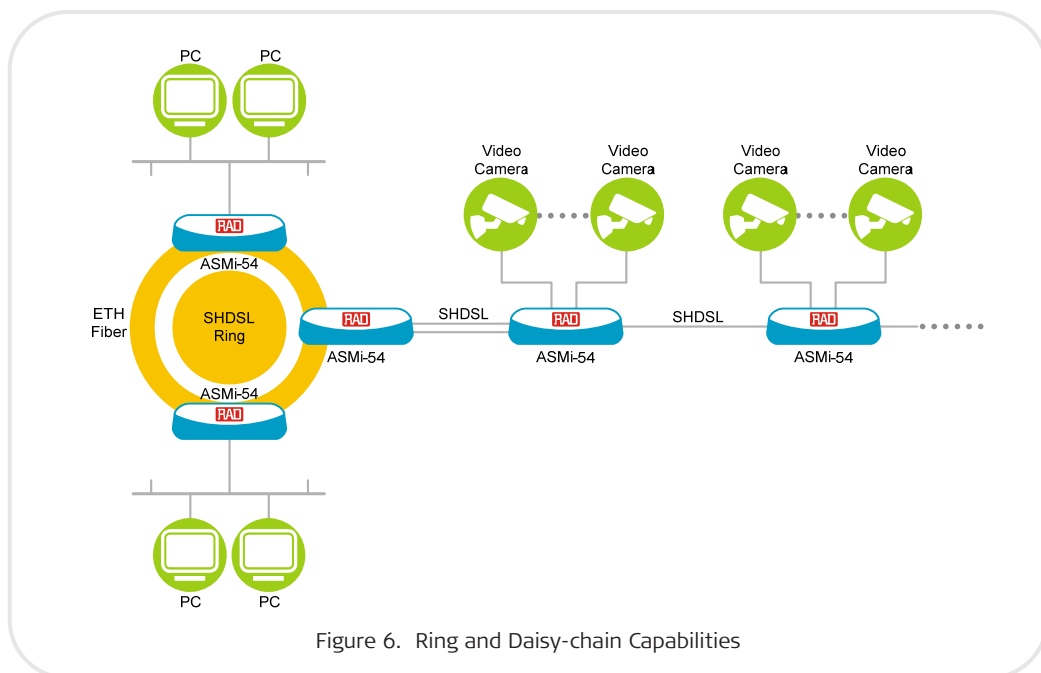

Figure 6. Ring and Daisy-chain Capabilities

ASMi-54

SHDSL.bis Modem

SUPPLIED ACCESSORIES

AC power cord
AC/DC adapter for -48 VDC

OPTIONAL ACCESSORIES

RM-33-2

Hardware kit for mounting one or two plastic ASMi-54 units in a 19-inch rack

RM-35/@

Hardware kit for mounting one or two 8.5-inch metal ASMi-54 units in a 19-inch rack

Legend

- @ Rack mount kit (Default=both kits):
 - P1 Mounting one unit
 - P2 Mounting two units

WM-35-TYPE4

Wall mounting kit for 8.5-inch units with metal enclosure





CBL-DB9F-DB9M-STR

Control cable

CBL-RJ45/2BNC/E1

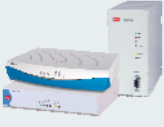
Interface adapter for converting a balanced E1 RJ-45 connector into a pair of BNC unbalanced coaxial connectors

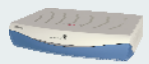
Modem Comparison Chart

Feature	ASMi-52 (Ver.2.98)	ASMi-52L (Ver.2.01)	ASMi-54 (Ver.3.51)	ASMi-54L (Ver.2.66)	ASMi-54LRT (Ver.2.1)
					
Max. data rate (Mbps)	2.3/4.6	2.3/4.6	5.7/11/22	5.7/11.4 (11.4/15 per pair with license key)	5.7/11/22
Interface	V.35, RS-530, X.21, E1, ETH	V.35, X.21, E1, ETH, 4 x ETH	4 x ETH, 4 x E1	4 x ETH, E1	4 x ETH, E1
Router	-	-	-	-	✓
Line	2W/4W	2W/4W	2W/4W/8W	2W/4W	2W/4W/8W

International Headquarters
24 Raoul Wallenberg Street
Tel Aviv 69719, Israel
Tel. 972-3-6458181
Fax 972-3-6498250, 6474436
E-mail market@rad.com

North America Headquarters
900 Corporate Drive
Mahwah, NJ 07430, USA
Tel. 201-5291100
Toll free 1-800-4447234
Fax 201-5295777
E-mail market@radusa.com

www.rad.com

Order this publication by Catalog No. 803759



data communications

The Access Company

503-100-06/12 (3.5) Specifications are subject to change without prior notice. © 1989-2012 RAD Data Communications Ltd. The RAD name, logo, logoType, and the terms EtherAccess, TDMoIP and TDMoIP Driven, and the product names Optimux and Ipmux, are registered trademarks of RAD Data Communications Ltd. All other Trademarks are the property of their respective holders.